

SE245 Dual Gel Caster



Page finder

Dual Gel Caster function and description.....	1
Unpacking	1
Prepare the gel caster.....	2
Construct the gel sandwich stack and place it into the caster.....	2
Pour the gel.....	5
Stacking gel preparation	6
After polymerization.....	7
Troubleshooting	8
Care and maintenance	8
Ordering information.....	9

Dual Gel Caster function and description

The SE245 Dual Gel Caster holds one or two glass or glass/alumina plate gel sandwiches for casting acrylamide gels. A cam seals the bottom of the sandwich against a rubber gasket. Once the gel is formed, sandwiches are transferred to a Hoefer mini-vertical unit for electrophoresis.

Unpacking

Unwrap all packages carefully and compare contents with the packing list, making sure all items arrived. If any part is missing, contact your local sales office. Inspect all components for damage that may have occurred while the unit was in transit. If any part appears damaged, contact the carrier immediately. Be sure to keep all packing material for damage claims or to use should it become necessary to return the unit.

Fig 1. Dual Gel Caster.

The gel sandwich is held together by the casting clamp assembly.

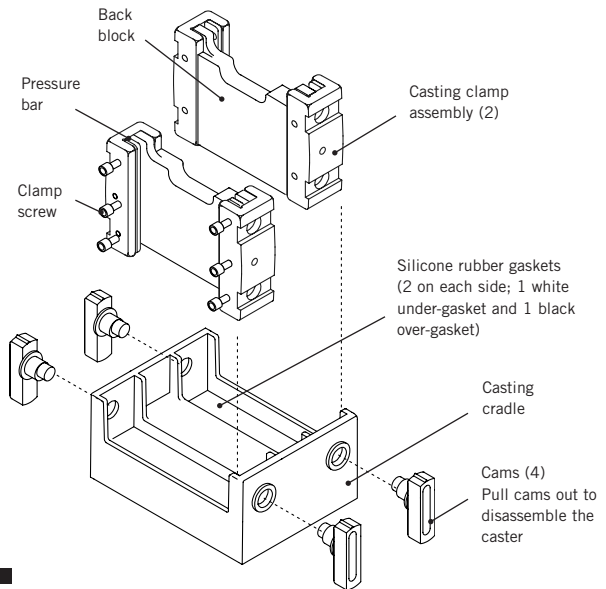

Prepare the gel caster

①

Disassemble the caster: Pull out both pairs of black cams at the side of the casting cradle and lift out both casting clamp assemblies. Remove the black silicone rubber gasket from the bottom of the cradle and also the white foam gasket underneath it.

②

Wash all gel caster components, glass and alumina plates and spacers with a mild detergent. Rinse thoroughly with deionized water.

Construct the gel sandwich stack and place it into the caster

①

Loosen all 6 screws on the casting clamp assembly and lay it upright on a flat surface. Slide both plastic pressure bars away from the back block.

②

Construct each gel sandwich: For each sandwich, choose one notched alumina or glass plate, one rectangular glass plate and two spacers. Use only unchipped plates.

Lay the notched plate on a flat surface, place one spacer along each edge so that it aligns with the notch. Fit a glass plate onto the spacers as shown. The long flat side of the T-shaped spacers fits between both plates. The top of the T rests along the sides of the plates (Fig 2).

Alternatively, assemble the sandwich while it is in a standing position: align the plate bottoms on a flat surface and align the spacers with the sides of the plates (Fig 3).

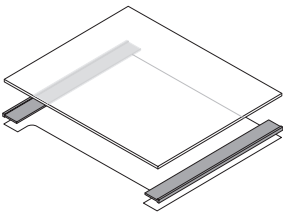

Fig 2. Location of T-shaped spacers on notched plate.

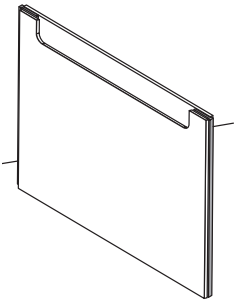

Fig 3. Align bottom edges of plates and spacers carefully.



3

Slide the sandwich into the casting clamp assembly, notched plate facing the back block, and plate bottoms flush with the flat surface.

4

While holding the sandwich in place, secure it by tightening all 6 screws until they are finger-tight. (To prevent breaking plates, do not over tighten.)

5

Inspect plate and spacer alignment. To prevent leaking, the bottom of the plates and spacers must be aligned and the sandwich should protrude slightly below the back block. Adjust if necessary.

6

Place the white foam gasket into the bottom of the casting slot and lay the black gasket over it.

7

Place the clamp assembly in the casting cradle, screw side facing out. In this position the gel will be visible through the rectangular glass plate.

8

Insert a cam into each hole on both sides of the casting cradle with the arrow (short end) pointing up. Seal the sandwich by turning both cams 180° so that the arrow points down.



Note: Wear gloves to keep the caster and plates free of finger marks.

Fig 4. 10 × 10.5 cm gel plates clamped properly for gel casting.

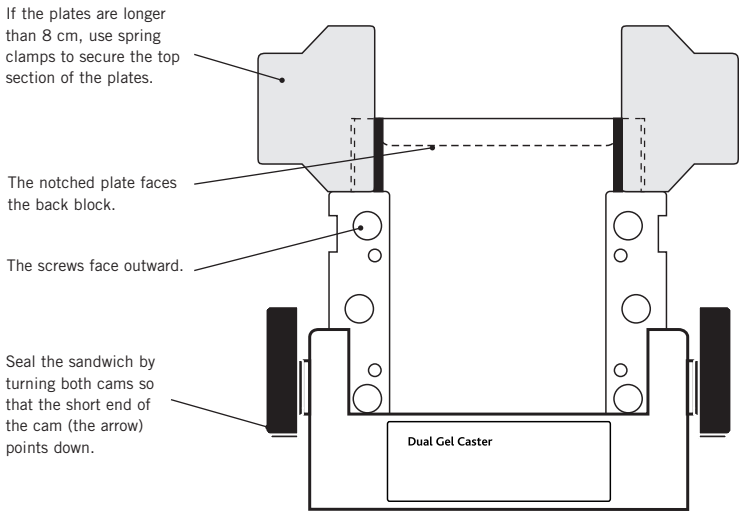

Important! The plate and spacer bottoms must be aligned for a proper seal.

Caution! Acrylamide is a neurotoxin. Always wear gloves and observe all laboratory safety procedures.

Pour the gel

①

Prepare the required amount of monomer solution. Deaerate and add the initiator and catalyst just prior to pouring the gel. Use a pipet to deliver the solution into one corner of the plate, taking care not to introduce any air pockets. See below for the appropriate solution level according to the application.

No stacking gel

Fill solution to just below the top of the notched plate. If air pockets form, remove with a pipet or syringe. Introduce a comb (at a slight angle) into each sandwich, taking care not to trap air bubbles under the teeth.

Stacking gel

Fill solution to 3 cm below the top of the rectangular glass plate. This height allows 1 cm of stacking gel below the wells. Pour the gel and apply an overlay. After the gel is polymerized, prepare the stacking gel as described below.

2-D electrophoresis

Fill solution to about 1.5 cm below the top of the rectangular glass plate and apply an overlay. This height allows 4–5 mm of space for the IPG strip and an agarose seal.

②

Overlay each gel with a thin layer of water-saturated n-butanol, water, or diluted gel buffer to minimize exposure of the top surface of the gel solution to oxygen. Deliver the overlay solution slowly from a glass syringe fitted with a 22-gauge needle. Apply the solution near the spacer and allow it to flow across the surface unaided.

③

Allow the gel to polymerize for a minimum of one hour.

Stacking gel preparation

Pour a stacking gel either while the sandwich is still in the gel caster or after it is transferred to the electrophoresis unit (see instrument instructions). Resolution is optimal when the stacking gel is poured just before electrophoresis. To pour a stacking gel in the dual gel caster:

1

Remove the overlay by rinsing the top of the gel several times with distilled water. Invert the caster to drain. To ensure a seamless contact between the separating and stacking gels, remove residual liquid by blotting one corner with a lint-free tissue.

2

Calculate the volume of stacking gel monomer solution required. Prepare the stacking gel monomer solution, deaerate it, and add catalyst and initiator.

3

Pour the stacking gel onto the resolving gel with a Pasteur pipet.

4

Introduce a comb (at a slight angle) into the sandwich, taking care not to trap air under the teeth. Allow the gel to polymerize.



After polymerization

1

To remove combs (if necessary): cover the top of the gel with 1X separating or stacking gel buffer, then work each comb out slowly by gently rocking it side to side while pulling it out.

2

Remove the gel sandwich from the casting cradle by loosening the pressure bar screws, tilting the sandwich forward, and lifting it out.

3

Rinse the sandwich with distilled water to remove the buffer and extra gel, then blot the sandwich with a lint-free tissue.

4

To run gels: Follow the instructions accompanying the electrophoresis unit.

To store gels: Wrap individual gels in plastic wrap after adding approx. 5 ml of 1X separating gel buffer to the top of each sandwich. Alternatively, lay a batch of gels in 1X separating buffer. Store gels at 4 °C for up to one week.

Troubleshooting

Gel sandwich leaks

- Replace any chipped plates.
- Check plate and spacer alignment and realign if necessary.
- Check the black gasket for cuts or cracks and replace if necessary.
- Apply a light film of Gel Seal to the bottom outside corner of each spacer.

Sample wells damaged or irregular

- Remove air pockets and bubbles before inserting combs. Slide comb into solution at an angle. If bubbles persist, remove comb, add more monomer solution and reinsert the comb.
- Allow a minimum of 1 hour for polymerization of acrylamide gels.
- Remove the comb at a slight angle and very slowly to prevent damage to the gel.

Care and maintenance

- Thoroughly wash and rinse all caster components immediately after use.
- Do not autoclave or heat any part above 45 °C.
- Do not use organic solvents, abrasives, strong cleaning solutions, or strong acids or bases to clean any plastic part.
- Do not soak the gaskets. Clean with a mild detergent and allow to air dry.

Clean glass plates and spacers with a dilute solution of a laboratory detergent such as RBS-35™ (Pierce Chemical Co.), then rinse thoroughly with tap and distilled water. Glass plates can also be treated with (but not stored in) acid cleaning solutions.

Important! Decontaminate instrument of all radioactivity and/or infectious agents before returning item! Include documentation to verify that this has been done.

Ordering information

product	quantity	code no.
----------------	-----------------	-----------------

Gel Caster and replacement parts

SE245 Dual Gel Caster, complete For 1 or 2 gels, 10 × 8, 10.5	1	SE245
Sealing gasket set	2	SE246
Casting clamp assembly	1	SE249
Cams, black	4	SE6005L
Clamps, red	4	SE252
Gel Seal, 1/4 oz.	1	SE6070

Glass and alumina plates

10 × 8 cm, for SE250

Notched alumina plate	1	SE202N
Notched alumina plates	10	SE202N-10
Rectangular glass plates	10	SE202P-10

10 × 10.5 cm, for SE260 and miniVE

Notched alumina plates	5	SE262N-5
Notched glass plates	5	SE262GN-5
Rectangular glass plates	5	SE262P-5

Spacers

	thickness (mm)	length (cm)	quantity	code no.
For SE250	0.75	8	2	SE2119T-2-.75
	1.00	8	2	SE2119T-2-1.0
	1.50	8	2	SE2119T-2-1.5
For SE260 and miniVE	0.75	10.5	2	SE2619T-2-.75
	1.00	10.5	2	SE2619T-2-1.0
	1.50	10.5	2	SE2619T-2-1.5

Combs

no. of wells	thickness (mm)	width (mm)		
5	0.75	13.0	1	SE211A-5-.75
5	1.00	13.0	1	SE211A-5-1.0
5	1.50	13.0	1	SE211A-5-1.5
9 ^a	1.00	5.8	1	SE211A-9-1.0
10	0.75	4.8	1	SE211A-10-.75
10	1.00	4.8	1	SE211A-10-1.0
10	1.50	4.8	1	SE211A-10-1.5
12	1.00	4.75	1	SE211A-12-1.0
15	0.75	2.9	1	SE211A-15-.75
15	1.00	2.9	1	SE211A-15-1.0
15	1.50	2.9	1	SE211A-15-1.5
18 ^a	1.00	2.9	1	SE211A-18-1.0
1/1 ^b	0.75	68/5	1	SE211A-R-.75
1/1 ^b	1.00	68/5	1	SE211A-R-1.0
1/1 ^b	1.50	68/5	1	SE211A-R-1.5

^aMicrotiter spacing, ^bPreparative/reference well

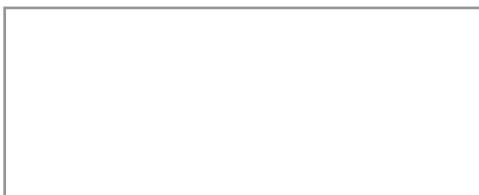

Hoefler Inc.

32 Scotland Blvd, Ste. 9,
Bridgewater, MA02324, USA
Toll Free: 1-800-813-0488
Phone: 1-508-807-4665
E-mail: support@hoeflerinc.com
Web: www.hoeflerinc.com

Hoefler is a registered trademark
of Hoefler, Inc.

RBS-35 is a trademark of Pierce
Chemical Co.

© 2023 Hoefler Inc.
— All rights reserved.

